

Pulsar™ EX20Rack / EX30Rack

User Manual

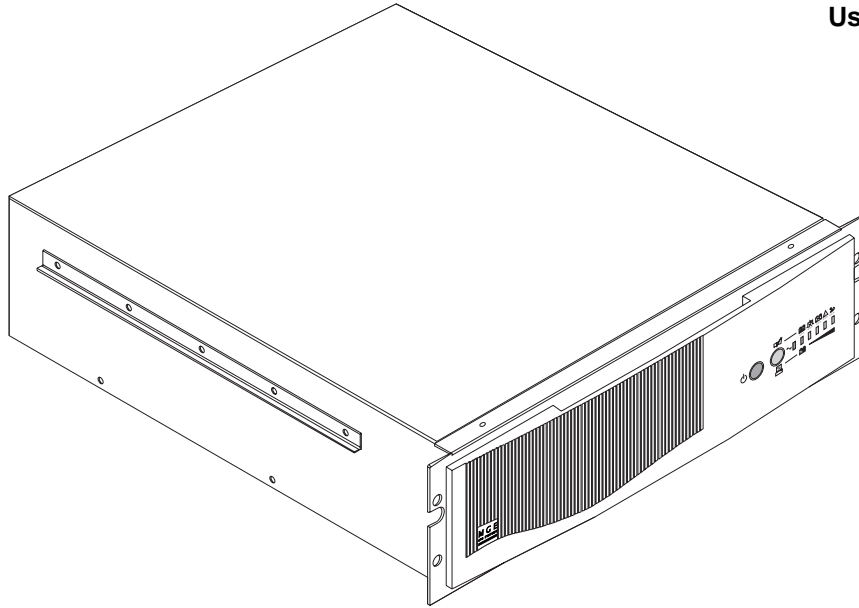

M G E
UPS SYSTEMS

www.mgeups.com

Thank you for purchasing the **EXRack** Uninterruptible Power Supply.

The **EXRack** has been designed to provide many years of trouble-free operation. Please review the manual which has been prepared to provide you with all the necessary information concerning the installation and use of your **EXRack**.

For service call 1-800-523-0142.

Sincerely,

MGE UPS SYSTEMS

Federal Communications Commission (FCC) Statement

Note: this equipment has been tested and found to comply with Part 15 of the FCC Rules. These limits are designed to provide reasonable protection against harmful interference when equipment is operated in a residential environment. This equipment generates, uses and can radiate radio frequency energy and, if not installed and used in accordance with the instruction manual, may cause harmful interference to radio communications. Properly shielded and grounded cables and connectors must be used in order to meet FCC emission limits.

IMPORTANT SAFETY INSTRUCTIONS

SAVE THESE INSTRUCTIONS

This manual contains important instructions for Models EX20Rack / EX30Rack / EXB20/30 that should be followed during installation and maintenance of the UPS batteries.

■ This equipment can be operated by any individual, with no previous training;

■ **CAUTION:** Risk of electric shock, even with unit disconnected from AC power source. Hazardous voltage still may be present through operation from battery. The battery supply should be disconnected at the plus and minus terminals using the quick disconnect connectors of the battery when maintenance or service work inside the UPS is necessary.

■ **The UPS contains voltages which are potentially hazardous. All repairs should be performed by qualified service personnel only;**

■ **do not attempt to power the UPS from any receptacle other than a 2-pole 3-wire grounded receptacle;**

■ do not place **Pulsar** near water or in environment of excessive humidity;

■ do not allow liquids or any foreign objects to get inside **Pulsar**;

■ do not block air vents in front or back of **Pulsar**;

■ do not plug household appliances such as hair dryers to **Pulsar** receptacles;

■ do not place **Pulsar** in direct sunlight or close to a heat-emitting source;

■ the AC power receptacle should be near the equipment and easily accessible. To isolate **Pulsar** from AC input, remove the input power cord from the AC power receptacle;

■ if **Pulsar** is to be stored for a long time, it is recommended to recharge the batteries (by connecting AC power source to **Pulsar**, switch "ON" or "OFF"), once a month for 24 hours to avoid a full battery discharge;

■ **Pulsar** contains batteries that should be disposed of or recycled in accordance with local applicable laws;

■ prior to installation, store **Pulsar** in a dry location;

■ storage temperatures must be between -4°F (-20°C) and +113°F (+45°C);

■ servicing of batteries should be performed or supervised by personnel knowledgeable of batteries and the required precautions. Keep unauthorized personnel away from batteries;

■ when replacing the batteries, use the same number and the following type of batteries:

□ **Pulsar EX20Rack:** 8 x 12V - 7.2Ah,

□ **Pulsar EX30Rack:** 8 x 12V - 7.2Ah;

■ ~ : alternating current supply symbol;

■ **CAUTION:** do not dispose of battery or batteries in a fire. The battery may explode;

■ **CAUTION:** do not open or mutilate the battery or batteries, released electrolyte is harmful to the skin and eyes. It may be toxic;

■ **CAUTION:** a battery can present a risk of electric shock and high short circuit current.

The following precautions should be observed when working with batteries:

□ remove watches, rings or other metal objects,

□ use tools with insulated handles,

□ wear rubber gloves, boots and safety glasses;

■ please dispose of the packaging in accordance with applicable laws.

introduction

In critical situations, count on MGE UPS SYSTEMS **Pulsar EX20Rack** and **EX30Rack** uninterruptible power supplies (UPS). Their protection keeps your data intact and accessible.

Pulsar EX20Rack and **EX30Rack** UPSs ensure top quality power around the clock, and continue operations during power failures. An intelligent microprocessor detects any operating anomalies of the UPS and triggers an alarm if corrective action is necessary.

In addition to the high-technology aspect of these UPSs, you can count on backup from our staff, a team of specialists, around the corner from you, throughout the world. It's no accident that MGE UPS SYSTEMS is the world leader in UPS protection. The UPS provides power factor correction to reduce harmonic distortion and current created by non-linear critical loads from polluting the incoming AC line.

UPS includes:

- batteries,
- power factor correction / battery charger,
- DC to DC converter,
- DC to AC inverter,
- bypass switch,
- input/output filters.

The MGE **Pulsar** UPS is capable of providing the following modes of operation:

■ **ON LINE MODE** which is the primary mode of operation in which the critical load is continuously supplied by the inverter and protected from all forms of power line disturbances:

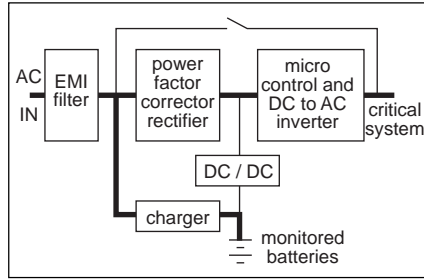

■ **BYPASS MODE** which is a default mode in the event of an inverter failure or overload in which the critical load is supplied AC through EMI/RFI filter:

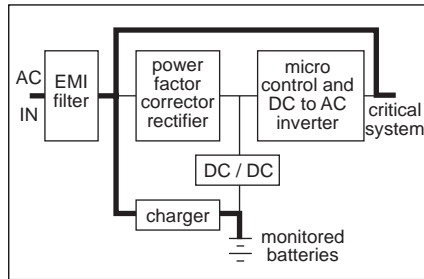

uses of Pulsar EX20Rack and EX30Rack:

Network servers and interconnection devices are very sensitive to electrical disturbances of all types, including outages, voltage sags, brownouts, spikes, etc. The origins of the disturbances also vary, ranging

from atmospheric phenomena, to nearby devices generating interference such as elevators, photocopy machines and machine tools, not to mention human errors, like the accidental pulling out of power cords or tripping of circuit breakers. The consequences of these disturbances on computer systems range from data losses to hardware damage (power supplies, hard disks).

Pulsar EX20Rack and **EX30Rack** are specially designed to protect network servers and all other interconnection devices that are sensitive to electrical disturbances. **Pulsar EX20Rack** and **EX30Rack** add fault-tolerance to the utility supplying your sensitive equipment.

Pulsar EX20Rack and **EX30Rack** are designed as compact units and feature very quiet operation.

Pulsar EX20Rack and **EX30Rack** provide a stable supply of clean power, long back-up time during a utility outage (see table) and vast information and control possibilities according to the configuration selected.

Pulsar EX20Rack and **EX30Rack** On-Line technology provides maximum protection and availability of workstations, servers, and network communication devices.

Pulsar EX20Rack and **EX30Rack** offer many functions and characteristics designed to simplify power management:

- automatic battery test carried out periodically. In the event of a fault, a LED provides advance warning for battery replacement;
- front panel LEDs signal all types of faults and alarms;

■ Bar graph continuously indicates the battery charge level or the critical load power level;

■ **Pulsar EX20Rack** and **EX30Rack** are environment friendly: all components are recyclable and an electronic power-saver device reduces power consumption if the UPS is not active for a period exceeding 5 minutes while on battery back-up;

■ EX Driver software provides rapid startup of **Pulsar EX20Rack** and **EX30Rack** using the EX Tuner configuration module. This module adapts **Pulsar EX20Rack** and **EX30Rack** to user preferences (battery test frequency, startup and shutdown sequences, setting of battery thresholds, etc.). See "communication" section for further details;

■ Solution-Pac™ is a CD-ROM which contains all the tools needed to supervise your UPS.

■ Simply download the EX driver utility from the CD and Solution-Pac. The UPS must be serially connected to a Windows PC.

options

■ **UM Sensor environment measurement unit:** compatible with SNMP or Solution Pac™, this unit measures the temperature and the relative humidity in the room where the **Pulsar** is installed. Eight relay contacts are provided to transmit signals to an administration platform, in the form of voltage-free contacts to enable monitoring of (fire alarm, climate control fault, intrusion, etc.);

■ **battery extension module: Pulsar EXB20/30** battery extension modules lengthen the battery time of the **Pulsar EX20Rack/EX30Rack** to meet your requirements. For rack installation of EXB20/30 order 19" rack kit P/N 8907U.

■ **output transformer:** input line cord plugs into the **Pulsar EX30Rack** output receptacle. Rating is 120V AC input, 208V/240V AC 2.75 kVA output;

■ **maintenance bypass switch:** enables the user to continue supplying ac power to the load while performing routine or emergency maintenance.

additional communications options:

■ **SNMP administration:** MGE has the most complete offering for the administration of a group of UPSs using the SNMP protocol with different network-connection modules (SNMP card or proxy software), supervision modules (application for NMS platforms such as HP OpenView or C.A. UNICENTER TNG) and a file-closing module (UM Client).

■ **SNMP card:** this card, inserted into your unit, can establish a direct Ethernet network connection for your UPS. It can then be temporarily managed using SNMP or the various software modules of Solution-Pac. The MGE UPS SYSTEMS offering complies with RFC 1628 specifications (IETF) and was certified by the InterWorking Labs during the Test Summit in June 1994;

■ **status information card:** this option provides you with 5 voltage-free contacts: on battery, on by-pass, low battery, load on UPS. This card can be used with the UPS driver of IBM AS/400.

Contact your dealer for further information on these options.

software supplied with Pulsar EX20Rack and EX30Rack

To meet the different operating environments of your UPS, **Pulsar EXRack** includes 2 MGE UPS SYSTEMS software programs:

- **EX-Driver** software for Windows
- **Network based Solution-Pac™** power management software

EX-Driver for Windows

EX Driver for Windows provides communication with the UPS from a simple Windows workstation. EX-Driver is compatible with Windows 3.1x and Windows 95/98, for communication with the UPS via a serial connection for various needs:

- **personalization of the UPS operating mode:** the EX-Tuner utility, can be used to change certain UPS operating parameters if the standard factory settings are not ideal for the operating conditions.
It is possible to modify the output voltage, battery-test frequency, startup and shutdown sequences, operation of automatic by-pass, etc.;

Solution-Pac™ for networks and multi-server systems

Protection by UPS is only complete and effective if combined with powerful software functions which warn users and the operator of any power supply problem, automate system shutdown, supervise and remotely control the UPSs. MGE UPS SYSTEMS created Solution-Pac™ for this purpose. Solution-Pac™ combines all these functions in a single CD-ROM, usable in local or remote mode (TCP/IP and SNMP), and covering the main network environments. Solution-Pac™ is the ideal solution for protecting networks and multiserver systems.

Solution-Pac™ on a single CD-ROM contains everything needed to safeguard one or more systems and to supervise one or more UPSs from a local or remote station. Solution-Pac™ includes SNMP proxy agents, system shutdown software, and supervision software.

Solution-Pac™ is a powerful and upgradable software tool which provides all the supervision, control and safety functions associated with a UPS:

- graphic display of the UPS,
- remote control of the UPS and output receptacles,
- user alarm of problems,
- recording of events in log files,
- automatic system shutdown and restart,
- local or remote supervision of UPSs and ancillary devices,
- transmission of UPS information and alarms to any SNMP supervisor.
- paging / e-mail capabilities
- multiple server shutdown in heterogeneous environment.

Platforms supported:

Windows 3.1, 95, 98, NT, Novelle Netware, OS/2, Linus, Mac/OS, Sun Solaris, HP/UX, IBM Aix, Dec Unix and Open VMS, Silicon Graphics, IRIX.

Pulsar presentation	3
getting started / operation	11

Pulsar EX20Rack / EX30Rack
front view

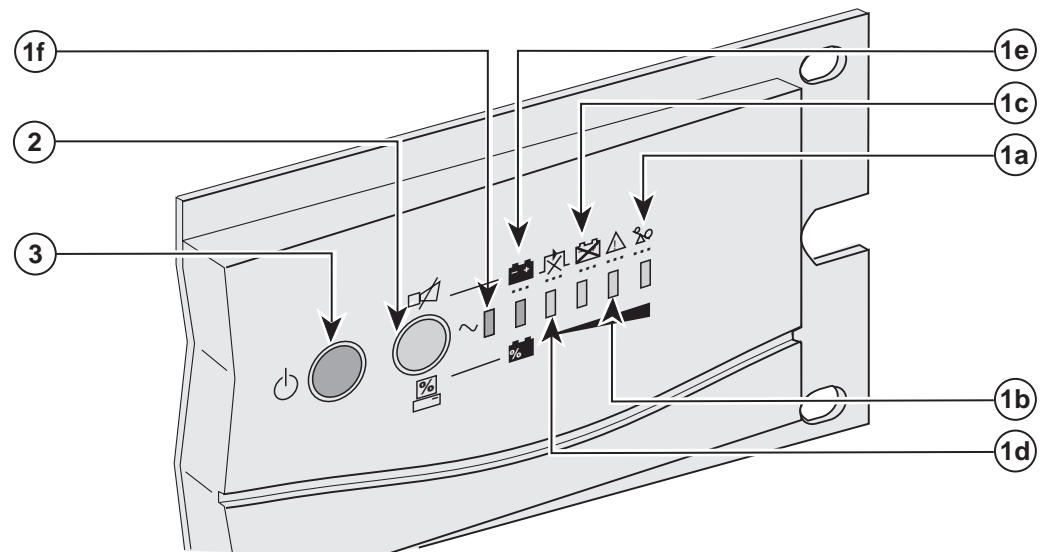

Pulsar EX20Rack
rear view

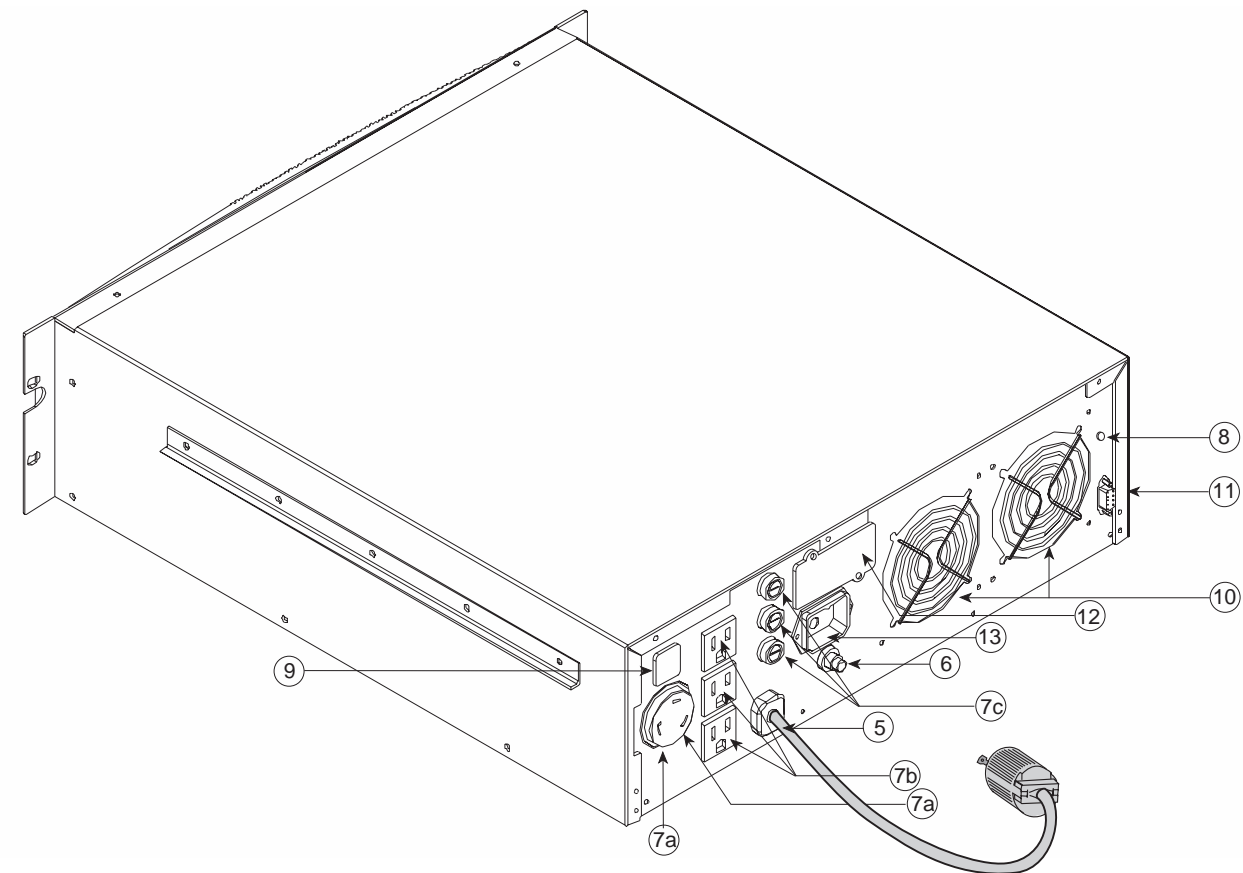

Pulsar EX30Rack
rear view

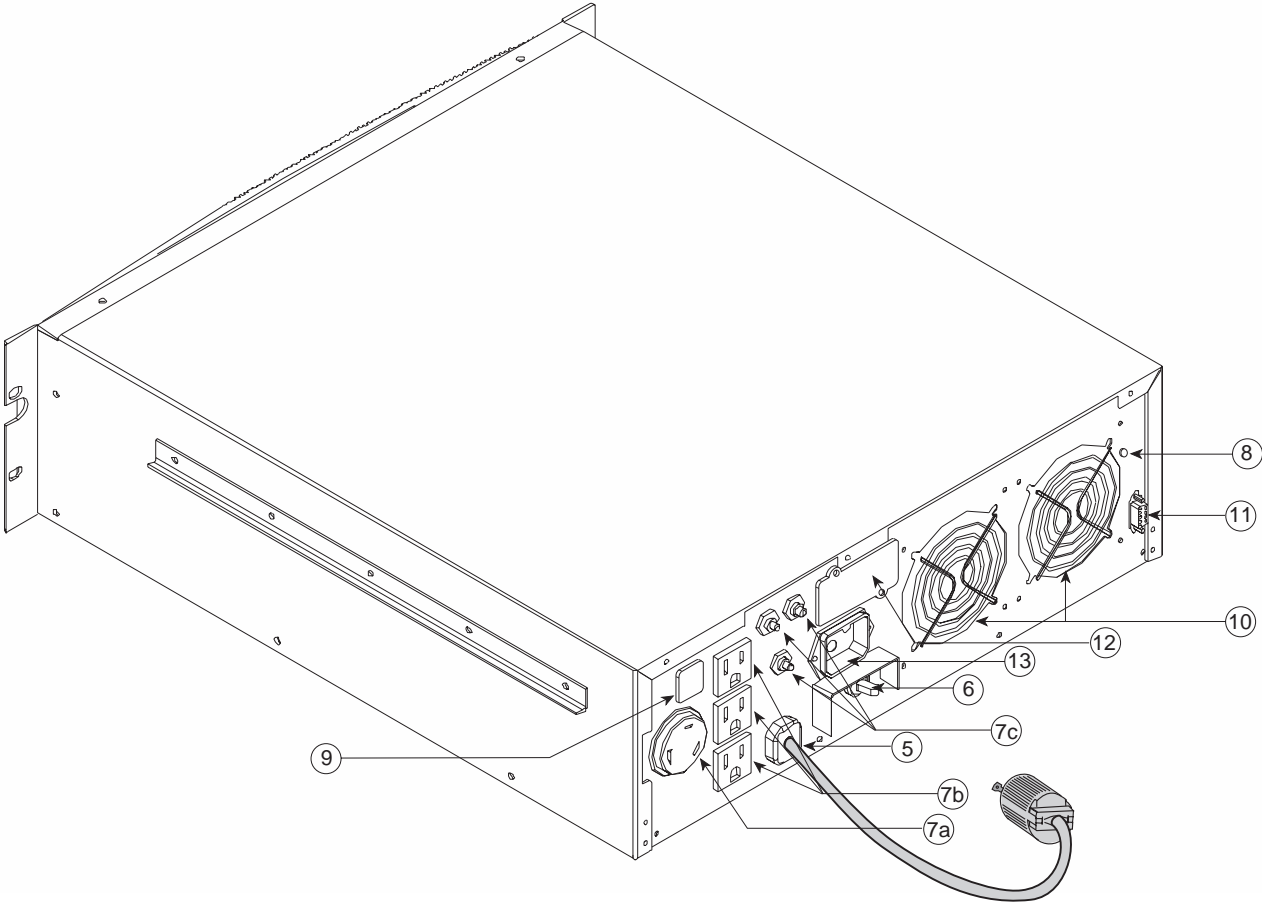

Pulsar EXB20/30 Extended Battery (See options for battery extension module on page iii.) rear view

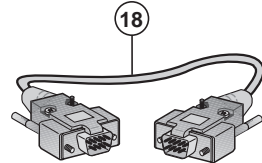
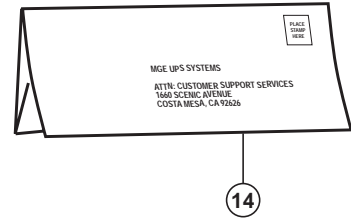
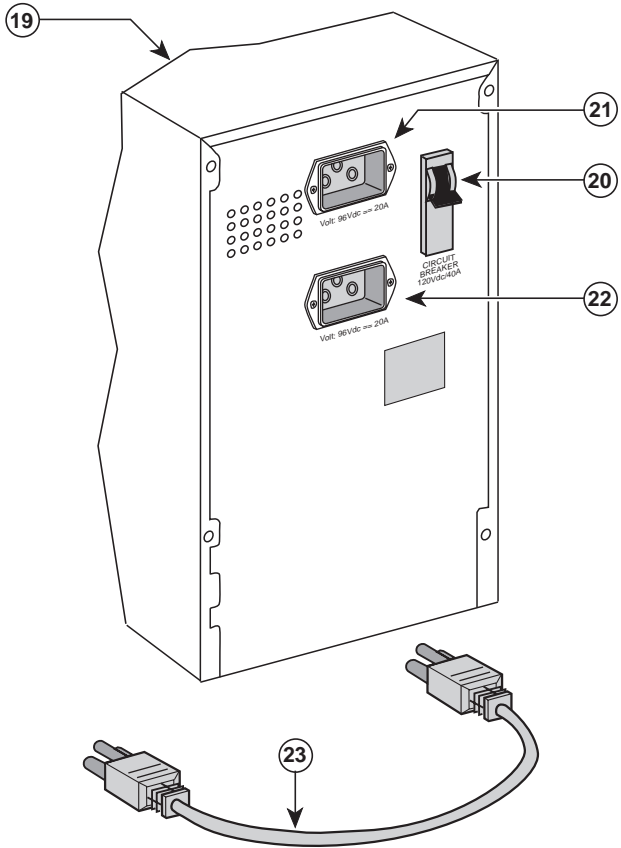

key to diagrams

yellow indicator LEDs (1a) to (1d) flashing quickly:

- (1a) overload,
- (1b) device fault,
- (1c) battery fault,
- (1d) operating on bypass (fault tolerant mode),

yellow indicator LEDs (1a) to (1d) continuously or flashing slowly: indicate the battery charge level (if utility power present) or remaining battery time (if no utility power present). They may be on continuously or flash slowly during a transition period. By pressing the button marked "function" (2) when utility power is present, they indicate the load charge level.

- (1e) green indicator LED flashing: operating on battery,
- (1f) green indicator LED on continuously: load powered by UPS, green indicator light off: load no powered by UPS,

- (2) "function" button: switches off audio warning device or measures load charge percentage (if utility power present),
- (3) "ON/OFF" switch:
button pushed in: ON
button not pushed in: OFF,
- (5) attached input cord,
- (6) input circuit breaker:
20A/125V for **Pulsar EX20Rack**,
30A/125V for **Pulsar EX30Rack**, -
L5-20 EX20R, L5-30 EX30R,
- (7a) twist-lock output receptacle for connection of computer loads to **Pulsar EXR**,
- (7b) output receptacles rated each 15A,
- (7c) **Pulsar EX20Rack**: T 15A/120V fuses to protect each (7b) output receptacles,
Pulsar EX30Rack: 15A/120V push to reset circuit breakers to protect each (7b) output receptacles,
- (8) site wiring fault LED,
- (9) rating label,
- (10) fans,

- (11) SUB-D 9 pin connector for U-Talk RS232 communication port,
- (12) cover for optional communication cards,
- (13) connector for **Pulsar EXB20/30** battery extension module,
- (14) warranty card,
- (17) Solution-Pac™ CD-ROM, EX Driver
- (18) RS232 cable,
- (19) **Pulsar EXB20/30** battery extension module,
- (20) battery circuit-breaker,
- (21) connector to **Pulsar EX20Rack/ EX30Rack**,
- (22) connector for second **Pulsar EXB20/30** battery extension module,
- (23) battery connection cord.

technical data

■ output power:

- Pulsar EX20Rack: 2000VA/1400W
- Pulsar EX30Rack: 3000VA/2100W

■ input voltage:

- voltage (V): ~ 90V to 138V single phase (70V to 138V at 1/3 Power, 80V to 138V at 2/3 Power)
- frequency (F): 47Hz to 53Hz or 57Hz to 63Hz

■ battery:

- type : maintenance free sealed lead-acid, 8 x 12V - 7.2Ah

caution: battery life (4 or 5 years) is halved every 10°C above 25°C

■ output specifications:

- voltage (V): ~ single phase 120V ± 3% (can be adjusted from 100 to 127V using EX Driver)
- frequency (F): 50/60Hz ± 0.5% (frequency configuration using EX Driver)

■ environment:

- noise level:  / ~ ≤ 50dBA for operation on utility power



≤ 50dBA for battery backup mode

- operating temperature:  0 to 35°C

- relative humidity:  0 to 90%
non condensing

■ dimensions and weights:

- height H (inches):

- width W (inches):

- depth D (inches):

- weight lbs (kg) 

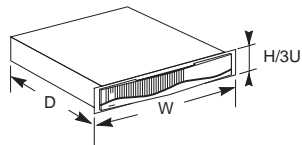

Pulsar EX20Rack

5.12

19

21.75

88(40)

Pulsar EX30Rack

5.12

19

21.75

92(42)

Pulsar EX20Rack battery back-up time

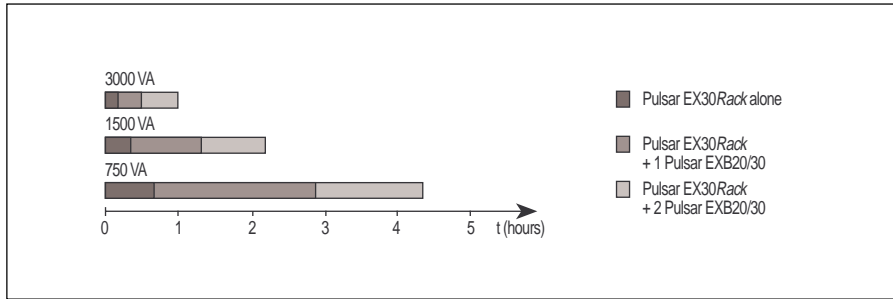

Pulsar EX30Rack battery back-up time

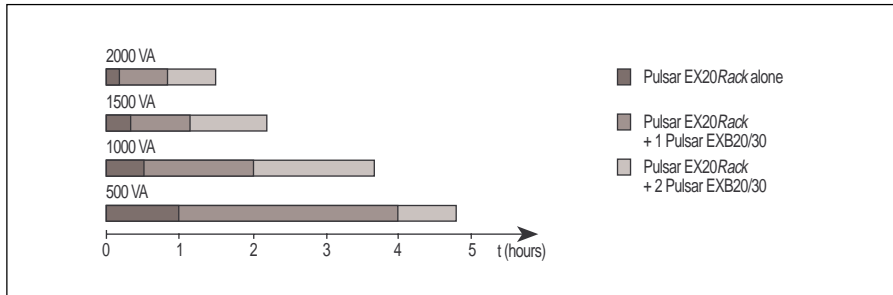

contents

- getting started** 12
- location 12
- preliminary checks 12
- connections 12
- communication 13

- operation** 14
- starting up with utility power present 14
- starting up with out utility power 15
- operation on battery 16
- overload 17
- operating anomalies 17

getting started

location

- observe the safety rules indicated at the beginning of this document.

preliminary checks

- check that the "on/off" button "ⓘ" on the front is not pushed in;
- check that rating shown on the rating label corresponds to the input voltage specification and power requirement of the load.

connections

- connect the AC input cord to the utility power outlet.

EX 20 Rack

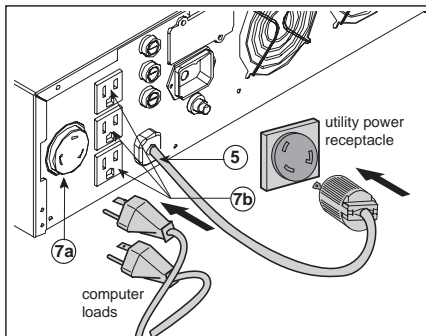

- connect the computer loads to output sockets **7a** or **7b**.

EX 30 Rack

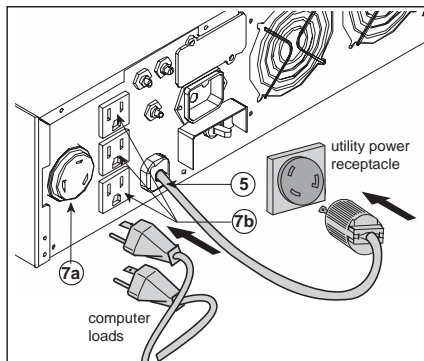

Note 1: following connection, the battery automatically charges, whenever plugged in.

Note 2: the batteries will provide full back-up time after approximately 8 hours of recharge time.

Note 3: if site wiring fault LED **8** is lit and audible alarm sounds, line/neutral connections are reversed.

■ connection of the Pulsar EXB20/30 battery extension module (optional):

- check that the button "on/off" "ⓘ" on the front of the Pulsar EX20Rack/EX30Rack is not pushed in,
- disconnect the input connection cord,
- flip the circuit-breaker of the battery unit to the right (position "O"),
- connect the battery connection cord to the DC connector of the battery module and connect to the **Pulsar EX20Rack/EX30Rack**,
- if the installation has 2 battery modules, connect the second cord to the DC connector of the second module and to the first module,
- the use of connectors is strictly limited to connecting the battery modules to the **Pulsar EX20Rack/EX30Rack**. Any other connection to these connectors is prohibited and risks damaging the battery, not covered by warranty,
- to start, flip the battery circuit-breaker to the left (position "I"),
- if your installation is operated with MGE UPS SYSTEMS software, update your battery configuration with EX Tuner.

communication

■ the U-Talk communication port, at the rear of the **Pulsar**, delivers information in the form of an RS232 series link supported by the communication protocol exclusive to MGE UPS SYSTEMS.

The Solution-Pac™ programs use the data made available by this protocol.

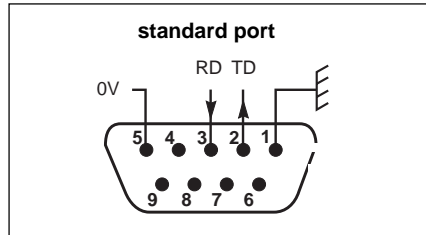

With the EX Driver software program you can set up **Pulsar EXRack** to suit your user conditions (EX Tuner). To install EX Driver, connect the serial cable supplied to COM1 to COM4 (set up by EX Tuner) serial port of your computer equipped with Windows 3.1 or 95/98 on the one end, and to the serial **Pulsar EXRack** connector on the other end. Insert the CD and type A:\Install. Follow the installation instructions on the screen.

option 1

■ **status information card:** after the card is installed in the rear of the **Pulsar**, communication port transmits the status information on a SUB-D 9-pin female connector using the following pinouts:

- 1 - ground,
- 2 - remote power off,
- 4 - normal operation,
- 5 - common,
- 6 - operation on utility power,
- 7 - low battery warning,
- 8 - load supplied by UPS,
- 9 - operation on battery.

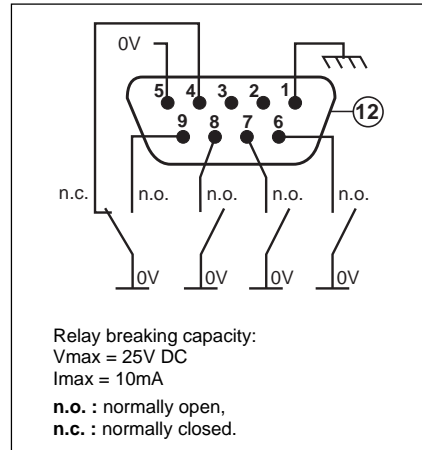

Note for remote power off information: Remove first J1 jumper on the status information board, then link your remote power off switch S1 between pins 2 and 5. Follow instructions from user's manual of the optional board for installation.

- switch ON: normal operation,
- switch OFF: unit stops immediatly.

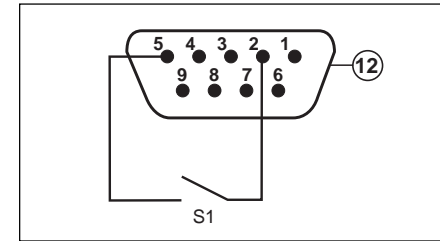

option 2

■ **SNMP card:** after the card is installed in the rear of the **Pulsar**, the communication port transmits information supported by the TCP/IP and SNMP protocols on an RJ45 connector to any Ethernet network.

Contact your sales agent for further details.

operation

starting up with utility power present

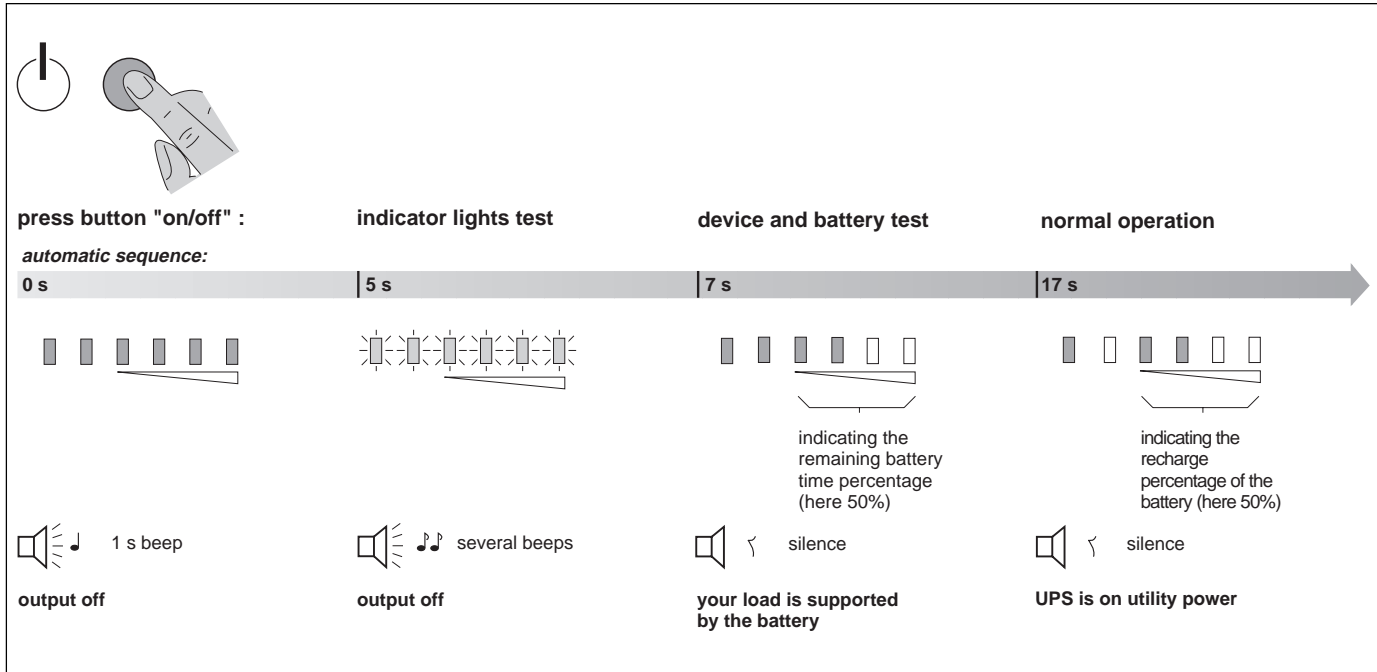

starting up with out utility power

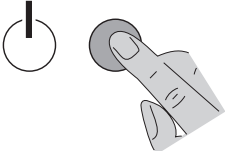

press "on/off" button:

automatic sequence:

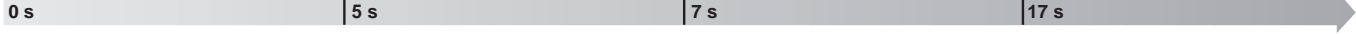

indicator lights test

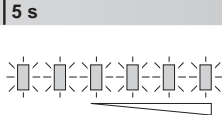

device and battery test

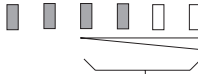

indicating the remaining battery time percentage (here 50%)

normal operation on battery

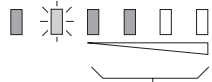

indicating the remaining autonomy percentage (here 50%)

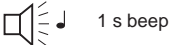

output off

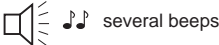

output off



your load is supported by the battery

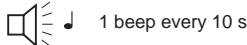

UPS is on utility power

operation on battery no utility power

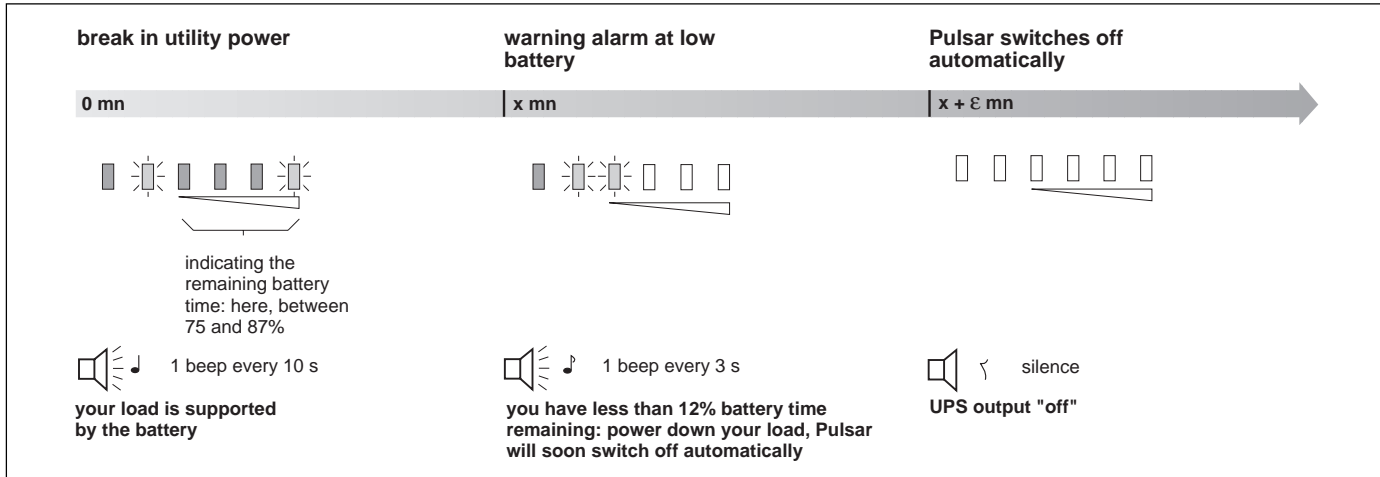

return of utility power

At whatever point the utility power returns, **Pulsar** switches to normal operation:

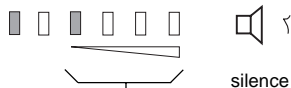

indicating the battery recharge percentage: here, between 12 and 25%

your load is supplied by the utility power (on line)

Note 1:

The "function" button is to deactivate or activate the audio warning device when operating on battery, or when site wiring fault occurred.

Note 2:

The "function" button allows you to force a transfer on bypass (push three times within 5 seconds) and to come back on normal operation (push again three times within 5 seconds).

load charge percentage

If utility power is present, hold alarm silence button in:

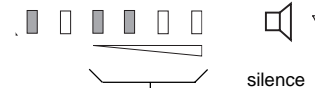

indicating the load charge percentage: here 50%

overload utility power present

1 beep
every
second

automatic load transfer to bypass

no utility power present

1 beep
every
second

Pulsar switches off automatically after a length of time which depends on the level of overload.

Note: overload occurs if the load consumption is greater than the rated power of Pulsar.

To acknowledge the fault, release the "on/off" button, temporarily disconnected Pulsar from the wall socket (check input cord), disconnect loads and re-start Pulsar.

operating anomalies device fault

1 beep
every
second

- automatic load transfer to bypass,
- switch off Pulsar (release "on/off" button), disconnect from the wall socket (check input cord), and check that Pulsar has not short-circuited (disconnect all loads),
- if necessary, change one of the fuses ,
- re-start Pulsar.

battery low

continuous
beep

after the start-up sequence, if the audio warning device sounds continuously,
recharge your battery for 8 hours.

Note: if the previous symptoms persist, contact technical support.

battery fault

A battery test is carried out while Pulsar, is in start-up mode, then automatically every 7 days (interval times adjustable using EX Driver). If a battery fault is detected, the following occurs:

1 beep
every
second

recharge your battery for 8 hours.

operation on bypass

1 beep
every
second

see "overload" and "device fault" section

Note: This operating mode provides temporary inverter fault tolerance.

service and factory repair - call 1 - 800 - 523 - 0142

■ direct questions about the operation, repair, or servicing of this equipment to MGE UPS SYSTEMS, Inc. Customer Support Services. Include the part number, and serial number of the unit in any correspondence. Should you require factory service, contact MGE UPS SYSTEMS, Inc. Customer Support Services and obtain a Return Materials Authorization (RMA) prior to shipping your unit.

proprietary rights statement

■ the information in this manual is the property of MGE UPS SYSTEMS, Inc., and represents a proprietary article in which MGE UPS SYSTEMS, Inc., retains any and all patent rights, including exclusive rights of use and/or manufacture and/or sale. Possession of this information does not convey any permission to reproduce, print, or manufacture the article or articles shown herein. Such permission may be granted only by specific written authorization, signed by an officer of MGE UPS SYSTEMS, Inc.;

■ Trademarks that may be used herein are owned by their respective companies and are referred to in an editorial fashion only.

two years warranty policy

■ MGE UPS SYSTEMS, Inc. (herein after referred to as MGE) warrants **Pulsar** equipment manufactured by MGE to be free from defects in materials and workmanship for a period of two years from date of purchase. If within such period purchaser discovers defective item and promptly notifies MGE in writing, MGE shall repair or replace the item at the Company's option. This warranty shall not apply:

□ to equipment not manufactured by MGE,

□ to equipment repaired or altered by others than MGE,

□ to equipment subjected to negligence, accident, or damage by circumstances beyond MGE's control, or to improper operations, maintenance, or storage, or to other than normal use or service.

With respect to equipment not manufactured by MGE, the Warranty obligations of MGE shall in all respects conform and Warranties do not cover reimbursement for labor, transportation, removal, installation, or other expenses which may be incurred in connection with repairs or replacement. Except as may be expressly provided in an authorized writing by MGE, MGE shall not be subject to any other obligations or liabilities whatsoever with respect to equipment manufactured by MGE or service rendered by MGE.

MGE UPS SYSTEMS, Inc.
www.mgeups.com

Postal address:
1660 Scenic Avenue
Costa Mesa, CA 92626
714-557-1636

86-153500-00